

Euro-Power Wirewound Series



HIGH
POWER

Vitreous Enamel Power

Select Euro series fixed resistors for applications requiring wattage ratings from 72 to 1000 watts. Suitable for rugged applications, Euro-Power resistors are spot welded producing stronger mechanical and electrical connections. The vitreous enamel coating was specifically developed and provides protection against moisture and mechanical damage. Euro-Power resistors are equipped with lug terminals suitable for soldering or sturdy bolt connection. Mounting brackets not included with resistors.

FEATURES

- Terminals suitable for soldering or bolt connection
- High wattage applications
- Rugged lead free vitreous enamel coating
- Flame resistant coating
- All-welded construction
- "Live" mounting option

SERIES SPECIFICATIONS

Series	Wattage	Ohms	Voltage	Construction
EVFT119	72	0.4Ω-250K	1400	Round wire
EVFT170	160	0.5Ω-100K	2100	Round wire
EVFT252	280	0.2Ω-125K	3300	Round wire
ESFT375	700	0.2Ω-200K	5000	Round wire
EVRT170	200	0.10-18Ω		Ribbon wire
EVRT252	350	0.22-33Ω		Ribbon wire
ESRT375	1000	0.33-56Ω		Ribbon wire

Non-Inductive versions available; Other sizes available; Also available in low cost Centohm or Silicone coating; Consult Ohmite.

CHARACTERISTICS

Coating	Lead free vitreous enamel. Very large models (700 watts and up) are supplied in Silicone Ceramic. Also available in low-cost Centohm coating; Consult factory.
Core	Tubular ceramic.
Terminals	solder coated radial lug with RoHS composition solder
Derating	Linearly from 100% @ +25°C to 0% @ +350°C.
Tolerance	±5% 1Ω and over (J); ±10% under 1Ω (K)
Power rating	Based on 25°C free air rating.
Overload	10 times rated wattage for 5 seconds.
Temperature coefficient	1 to 20Ω: ±400 ppm/°C; Above 20Ω: ±260 ppm/°C; Ribbon wire: 400ppm/°C
Dielectric withstanding voltage	1000 VAC: 72 to 160 watt rating. 3000 VAC: 280 to 700 watt rating (Measured from terminal to mounting bracket)
To calculate max. amps	use the formula $\sqrt{P/R}$

SOLDER TAB DIMENSIONS

(mm)

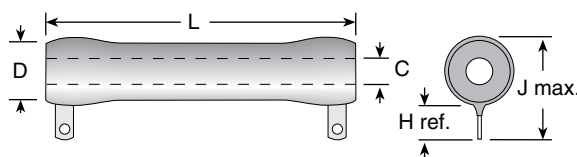

Wattage		L	D	C	H ref.	J max.	Core Code
Round wire	Ribbon wire						
72	N/A	119	20.3	9.2	14.3	39.4	EM
160	200	170	25.5	12.4	15.9	45.9	EN
280	350	252	30.6	17.5	19.1	54.1	EP
700	1000	375	51.0	27.9	19.1	74.1	ER

Euro-Power Wirewound Series

Vitreous Enamel Power

HIGH
POWER

LUG DIMENSIONS

(dimensions in millimeters)

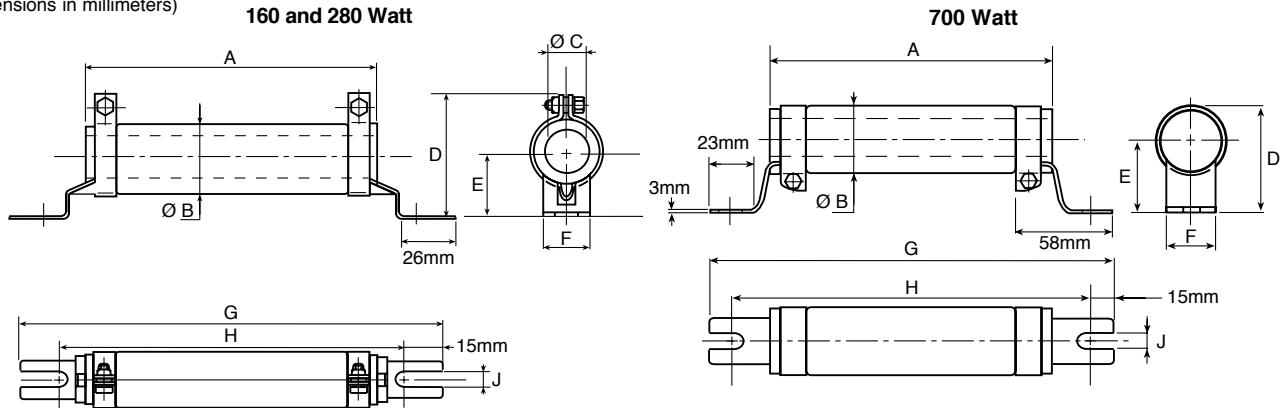

Watts		A ±2	Ø B max.	Ø C min.	D	E	F ±0.5	G -4/+0	H -4/+0	J ±0.5	Core code
Round wire	Ribbon wire										
160	200	168	28	12	53.8 ±1	27 ±1	24	229	199	6.5	EN
280	350	250	33	17	63 ±1	30 ±1	25	317	287	9	EP
700	1000	373	53	27.1	80 max.	51 ±1.5	30	432	405	9	ER

ORDERING INFORMATION

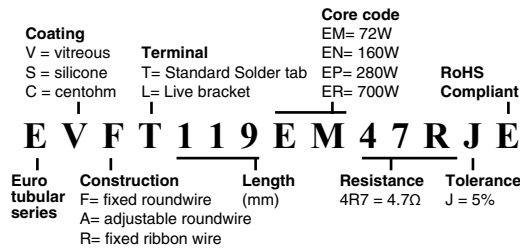

Standard Part numbers for Fixed Roundwire Euro series

EVFT119EM10RJE	EVFT170EN10RJE	EVFT252EP10RJE	ESFT375ER10RJE
EVFT119EM100JE	EVFT170EN100JE	EVFT252EP100JE	ESFT375ER100JE
EVFT119EM1K0JE	EVFT170EN1K0JE	EVFT252EP1K0JE	ESFT375ER1K0JE
EVFT119EM10KJE	EVFT170EN10KJE	EVFT252EP10KJE	ESFT375ER10KJE
EVFT119EM4R7JE	EVFT170EN4R7JE	EVFT252EP4R7JE	ESFT375ER4R7JE
EVFT119EM47RJE	EVFT170EN47RJE	EVFT252EP47RJE	ESFT375ER47RJE
EVFT119EM470JE	EVFT170EN470JE	EVFT252EP470JE	ESFT375ER470JE
EVFT119EM4K7JE	EVFT170EN4K7JE	EVFT252EP4K7JE	ESFT375ER4K7JE

Standard Part numbers for Fixed Ribbon wire Euro series

EVRT252EPR22KE	EVRT170EN2R2JE	ESRT375ER2R2JE
EVRT252EPR22KE	EVRT170ENR10KE	ESRT375ER4R7JE
EVRT252EP1R0JE	EVRT170EN4R7JE	ESRT375ER1R0JE
EVRT252EP2R2JE	EVRT170EN1R0JE	ESRT375ER10RJE
EVRT252EP10RJE	EVRT170EN10RJE	ESRT375ER22RJE
EVRT252EP22RJE	EVRT170ENR47KE	ESRT375ERR47KE
EVRT252EP4R7JE	EVRT170ENR22KE	ESRT375ER47RJE